

1 9 8 8

# FORD BRONCO II



B R O N C O I I

# FORD BRONCO II FOR 1988



**B**est-built American trucks seven years running. For the past seven consecutive years, Ford quality has led all other American automotive companies. That's based on an average of owner-reported problems in a series of surveys of '81-'87 models designed and built in North America. It's the result of our firm commitment to the integrity of the vehicles we produce.

Over the past several years, that commitment has led us to new state-of-the-art product developments, tooling and manufacturing procedures. Most important, we've formed a stronger partnership with our people — production workers and management — everyone pulling together with the goal of producing the right cars and trucks for your needs today. And the *right* car or truck is one that's designed and built with the highest quality.

The built-Ford-tough Bronco IIs you'll read about here are testaments to that quality effort. Available

in both 2-wheel drive and 4-wheel drive versions, they're engineered to provide outstanding performance and value in an expanding market. All Bronco IIs have V-6 power with multi-port electronic fuel injection. They also have a sophisticated rear anti-lock brake system. Our products, backed by a 6-year/60,000-mile powertrain warranty, are making the definitive statement about Ford quality and our customer-driven attitude.

And the effort is ongoing. Constantly striving for new and better ways of serving our customers, we have looked toward the global marketplace.

Our abundance of worldwide resources will help us continue to produce high-quality, affordable products.

A lot has been happening at Ford over the past several years. It's all summed up in a familiar little credo which has come to mean *exactly* what Ford Motor Company is all about: *Quality is Job 1.*



## Contents

Eddie Bauer Bronco II .....	2, 4-5
Bronco II XL, XL Sport and XLT .....	6-7
Bronco II Engineering Excellence .....	8-9
Preferred Equipment Packages .....	10-11
Features, Options and Colors .....	12-13
Safety and Owner Information .....	14-15

**Eddie Bauer Bronco II** in Scarlet Red/Chestnut two-tone paint. Some equipment shown may be optional. See options list on page 13.

# THE SPECIAL LOOK OF FORD EDDIE BAUER BRONCO II



**E**ddie Bauer is the top-of-the-line Bronco II, named after the world-famous designer of high-quality outdoor gear and leisure wear. Specially appointed, specially trimmed and ready for the great outdoors, it's a real standout among compact utility vehicles.

#### **A unique color scheme**

Outside, there's a distinctive Eddie Bauer two-tone paint treatment (shown on the cover and on page 2) which is available in five color combinations. Larger P205 RWL all-season radial tires are standard, and they're matched with handsomely styled cast aluminum wheels.

#### **Extensively equipped**

All the comfort that's built into the Bronco II XLT series is also in Eddie Bauer, along with some notable additions. Dual reclining front Captain's Chairs include a special cloth with vinyl fabric and feature power lumbar supports. Air conditioning, Privacy glass™ quarter windows, speed control and tilt steering wheel are all included. And unique Eddie Bauer garment and gear bags, trimmed in tan cloth and leather, are shipped directly to you from Eddie Bauer.

#### **An important "extra"**

The "Ford Care" extended maintenance and limited warranty program, which offers coverage up to 24 months or 24,000 miles, is also part of the Eddie Bauer package. This is in addition to Bronco II's 6-year/60,000-mile powertrain coverage. Ask your Ford Dealer for full details on this limited warranty. While you're there, take the time to test drive an Eddie Bauer or any other Bronco II. Experience all that a compact utility vehicle can be.



*Eddie Bauer instrumentation in Chestnut.*



*Like all Bronco IIs, the Eddie Bauer rear seat features a split/fold design for cargo/passenger versatility.*

*Eddie Bauer Bronco II interior in Chestnut.*

*Some equipment shown on these pages may be optional. See options list on page 13.*

B R O N C O I I

# BRONCO II XL, XL SPORT AND XLT SERIES



*Some equipment shown on these pages may be optional. See options list on page 13.*

**Bronco II XL Sport in Silver Clearcoat Metallic.**

**B**ronco II XL, with its handsome list of standard features (page 13), is joined in 1988 by the XL Sport. Free-spirited Sport is easily identified by its distinctive outfitting, including a brush/grille guard, fog lamps, black tubular rear bumper, black front bumper (in place of the standard bumper), spats and front fascia. These items are optional with Bronco II XLT as well. They're called the Sport Appearance Package.

#### **XLT additions**

XLT is the comfort/convenience-oriented Bronco II. It includes cloth and vinyl upholstery, wrapover cloth door panels with map pockets and other trim extras. Also standard are the handy Light Group (detailed on page 13), an AM/FM stereo radio with digital clock, pivoting front vent windows and more.

#### **Versatile Bronco II**

Whichever Bronco II series you choose, you can be assured of a comfortable, well-equipped vehicle, V-6 powered and fitted with an electronically controlled anti-lock rear brake system (page 8).



*Bronco II XLT in Light Chestnut/Dark Chestnut Clearcoat Metallic deluxe two-tone paint.*



*Bronco II XL interior in Regatta Blue.*



*Bronco II XLT interior in Chestnut.*

# ENGINEERING EXCELLENCE

## BRONCO II 2WD AND 4WD

**F**ord Bronco II employs today's technology to help its driver. The electronically controlled rear anti-lock brake system is designed to inhibit complete rear wheel lock-up under most operating conditions. Whenever rear wheel lock-up is detected, the computer processes signals and directs the pressure control valve to selectively modulate rear brake line hydraulic pressure. The result is enhanced driver ability to control braking performance (see illustration).

### Spirited V-6 power

All Bronco IIs feature the 2.9 liter V-6 engine with its 140-horsepower output. It includes a multi-port fuel injection system (EFI) which is efficiently governed by the Ford-designed EEC-IV engine control computer. A sporty 5-speed manual overdrive transmission, standard, is synchronized in all gears — including reverse.

When it comes to towing, Bronco II allows for a gross combination weight rating (GCWR) of 8,500 pounds and a maximum trailer weight rating of 5,100 pounds in the 2WD model (5,000 pounds in the 4WD).\* A properly equipped Bronco II for this kind of towing includes the Automatic Overdrive transmission, 4.10 limited-slip rear axle, and the Super Engine Cooling Package.

*The controls for the optional 4WD Touch-Drive are conveniently located in an overhead console.*



### Overdrive efficiency

The optional 4-speed automatic overdrive transmission (A4LD) provides a mechanical lock-up which eliminates power-wasting torque converter slippage, especially during highway travel. The electronically controlled converter clutch automatically engages during steady-speed operation in fourth gear and the upper range of third gear.

### Special shocks for a smooth ride

All Bronco II models are equipped with gas-pressurized shock absorbers designed to help maintain proper hydraulic fluid pressure, even over a rapid succession of jarring bumps. The ride is smooth under normal circumstances, yet firm enough over rough road conditions.

### Manual locking hubs

The 4WD standard free-running front hubs are the manual locking type. When the wheel hubs are locked, you can shift "on the fly" from 2-wheel high to 4-wheel high and back again to suit driving conditions.

### The Touch-Drive option

Touch-Drive is the ultimate convenience for 4-wheel driving enjoyment. It allows shifting "on the fly" from 2-wheel high to 4-wheel high and back at any speed just by touching a button. The automatic locking hubs engage instantly because Touch-Drive employs an innovative magnetic clutch that spins up the front drive system from zero to driving speed in milliseconds.

Two special electrical interlocks prevent possible powertrain damage that might otherwise be caused by a mis-shift between 4-high and 4-low. Shifting into or out of 4-low can only be done when the vehicle is either stopped or moving below 3 mph with the manual transmission clutch disengaged or the automatic transmission in neutral.

*\*Reduced by passenger and cargo weight in the towing vehicle.*

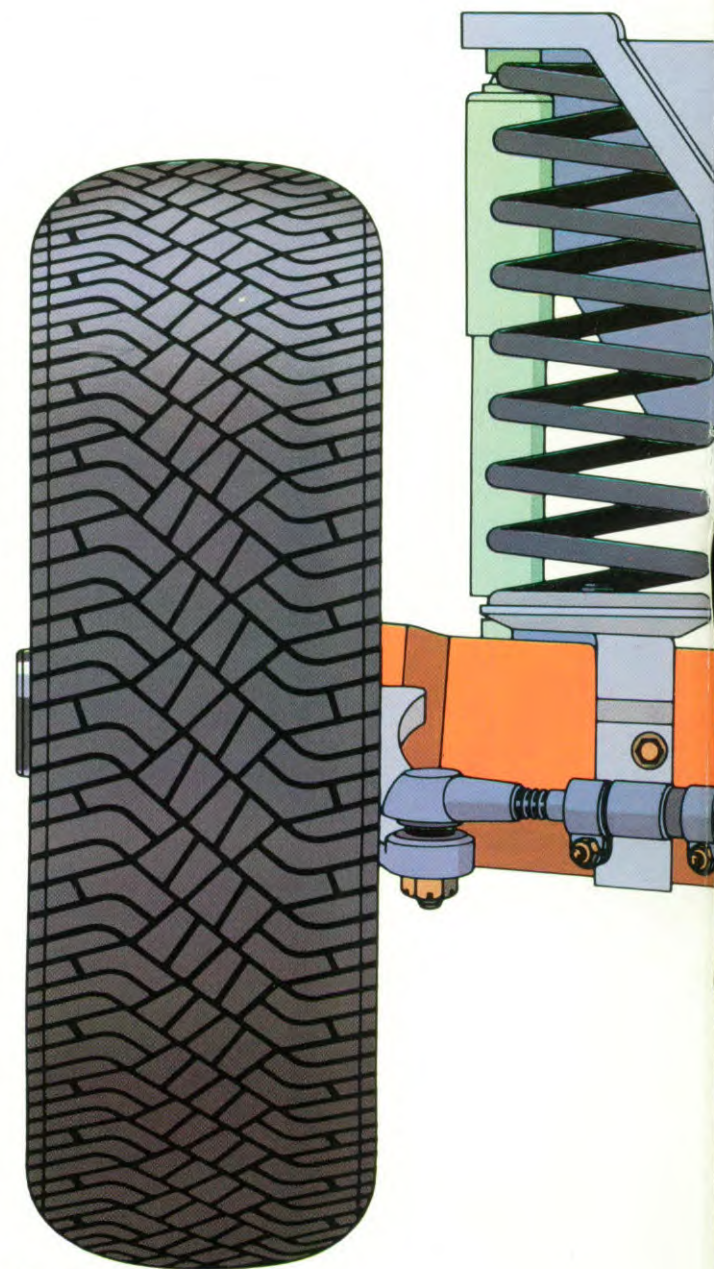

*Ford-famous Twin-I-Beam independent front suspension is standard with the 2WD model and the Twin-Traction Beam system (shown above) with the 4WD. Each front wheel, with its own axle and hefty coil spring, steps over bumps independently to help cushion the ride and provide excellent handling.*





**V-6**  
performance  
makes  
Bronco II  
a great vehicle  
for recreational  
towing of  
all sorts.

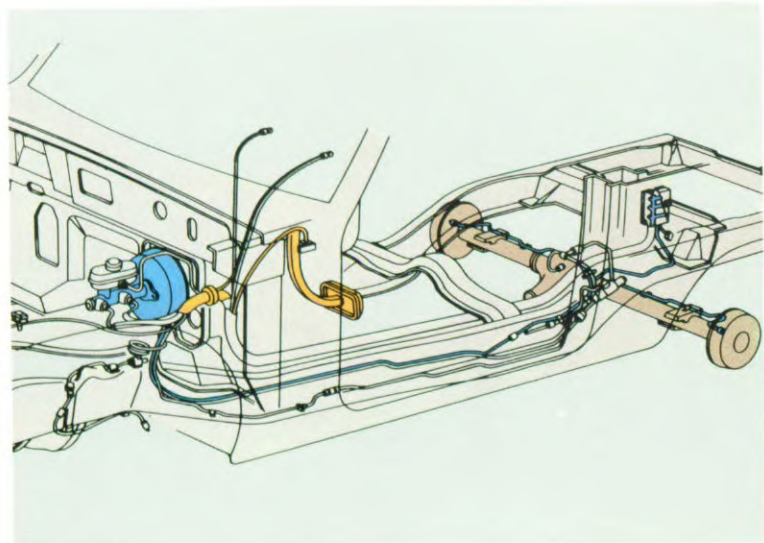
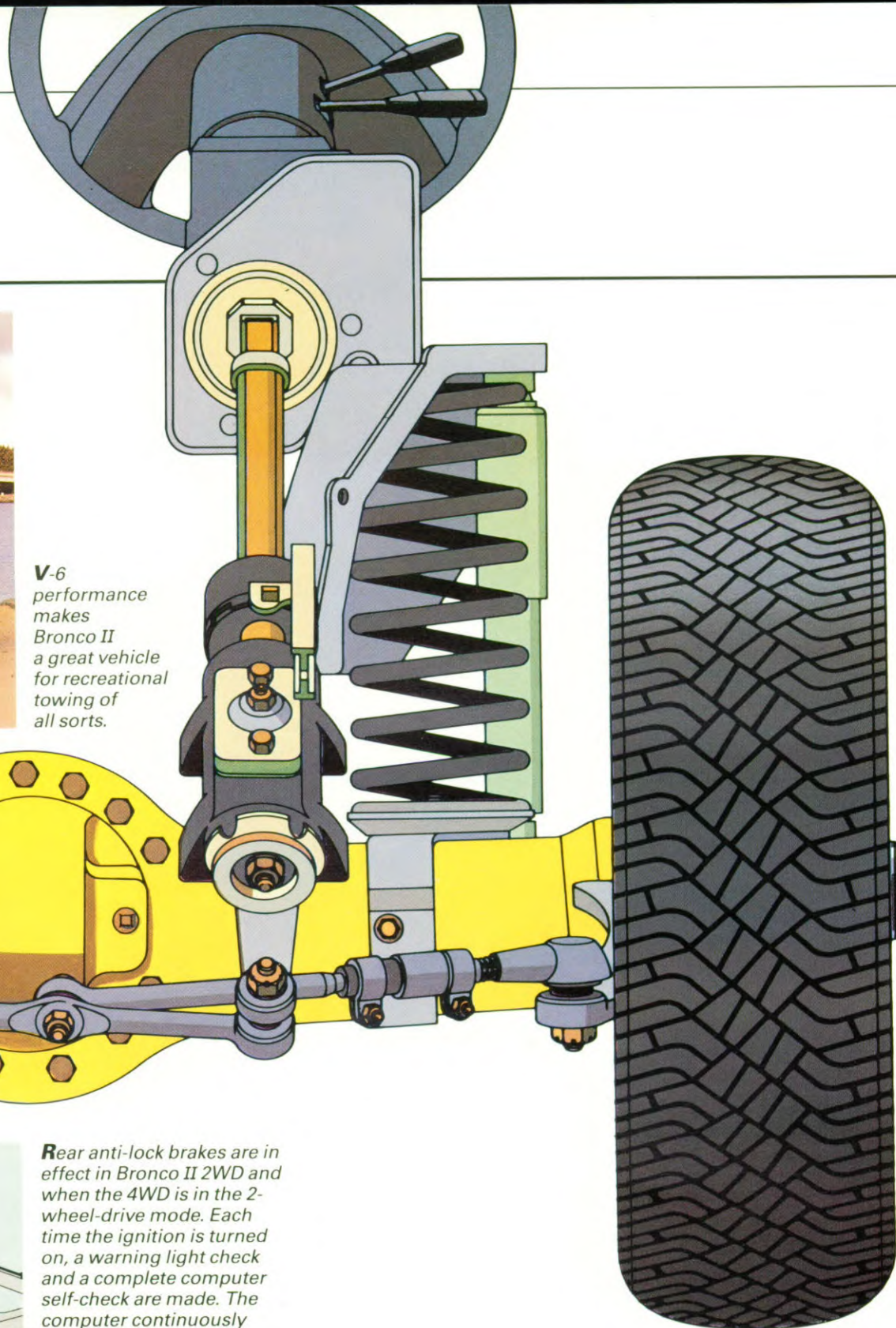

**Rear anti-lock brakes are in effect in Bronco II 2WD and when the 4WD is in the 2-wheel-drive mode. Each time the ignition is turned on, a warning light check and a complete computer self-check are made. The computer continuously checks for any possible electrical malfunction. In the unlikely event of a malfunction, the warning light on the instrument panel will alert the driver that the computer has automatically shut down the system and converted the rear brakes to conventional braking operation.**

# PREFERRED EQUIPMENT PACKAGES

**T**he Bronco II XLT at right illustrates the high level of equipment in this series. Included is Preferred Equipment Package 931A which features air conditioning at no extra cost and more (see below), making this XLT an outstanding value.

## An easy way to buy

Preferred Equipment Packages are groups of popular features. By combining them, we simplify the ordering procedure. All you have to do is: (1) Decide on the trim level (XL, XL Sport, XLT or Eddie Bauer); (2) Select the Preferred Equipment Package from the chart at right that includes the features you want.

## Air conditioning at no extra cost

Bronco II packages 923A, 931A and 934A contain special discounts. Order 923A and save an amount equivalent to getting air conditioning at no extra charge. Order 931A or 934A and save even more. Your dealer can explain these savings, which are based on the manufacturer's suggested retail price of the package compared to the price of the items if purchased separately.

## Special Value Packages

There are also special discounts offered on certain XL, XL Sport and XLT models equipped with the fun-to-drive 5-speed manual overdrive transmission. It's like getting one or more desirable items of equipment at no additional charge (see chart at right).

Once you've settled on a Preferred Equipment Package or Special Value Package, you can further personalize your new Bronco II by referring to the listing on page 13. It contains the free-standing options available to you as well as a summary of notable standard features.

Bronco II	Preferred Equipment Packages				
	XL 921A	XL Sport 922A	XLT 923A 931A		Eddie Bauer 934A
Electronic AM/FM stereo radio with digital clock	•	•	•	•	•
Light Group (1)	•	•	•	•	•
Deluxe wheel trim	•		•	•	
P205/75Rx15SL RWL all-season steel-belted radial tires		•		•	•
Sport Appearance Package		•			
Tachometer		•	•	•	•
Deep-dish cast aluminum wheels		•			
Air conditioning			•	•	•
Privacy glass™ quarter windows				•	•
Power windows and door locks				•	•
Speed control/tilt steering wheel				•	•
Deluxe two-tone paint				•	•
Rear window defroster/wiper-washer					•
Flip-open rear window				•	
Electronic AM/FM stereo radio with cassette tape player and digital clock					•
Outside swingaway spare tire carrier/cargo cover					•
• = Included in package or standard					

(1) Includes lights for ashtray, glove box, cargo area, engine compartment, plus headlamps-on alert chime.

## MANUAL TRANSMISSION SPECIAL VALUE PACKAGES

If you buy certain Bronco II XL, XL Sport and XLT models with a manual transmission special value package, you qualify for discounts which are equivalent to getting some or all of the following options at no extra charge:

- Air conditioning
- Electronic AM/FM stereo radio with cassette tape and digital clock
- XLT accent tape stripe
- Deluxe wheel trim
- Outside swingaway spare tire carrier/cargo cover
- Luggage rack
- P205/75Rx15SL RWL all-season radial tires

See your dealer for details on this money-saving way to get extra Bronco II driving enjoyment.

**Bronco II XLT in Shadow Grey  
Clearcoat Metallic/Silver Clearcoat  
Metallic deluxe two-tone paint.**

Some equipment shown may be optional. See options list on page 13.



# PERSONALIZED OPTIONS

In addition to Preferred Equipment Packages, Bronco II offers a wide selection of individual options which allows you to equip your vehicle even more to your particular needs. (Remember that some of these options are already included in Preferred Equipment Packages on page 10.) Check the listing on page 13 for the availability of free-standing options.

Options and their availability are subject to change during the year. Some options may be subject to ordering restrictions. Your Ford Dealer can give you complete details.

Pictured at right are selected options that may be of particular interest.



Speed control/tilt steering wheel.



Electronic AM/FM stereo radio with cassette tape player.



Power windows and door locks.



Cast aluminum wheels (15"), deep-dish cast aluminum wheels.



Sport tape stripe.

## SPECIFICATIONS

Equipment		2WD	4WD
Powerteams	Std.	2.9L EFI V-6/5-Spd. Man. OD	2.9L EFI V-6/5-Spd. Man. OD
	Opt.	2.9L EFI V-6/4-Spd. Auto. OD	2.9L EFI V-6/4-Spd. Auto. OD
Fuel tank (gals.)	Std.	23	23
Electrical:			
Battery (amp-hr.)	Std.	71 maintenance-free	71 maintenance-free
Alternator (amp)	Std.	60	60
Steering	Std.	Power	Power
Brakes	Std.	Power	Power
Frame	Std.	Ladder-type	Ladder-type
Axles, front	Std.	2,200 lb. Twin-I-Beam	2,750 lb. Twin-Traction Beam
rear	Std.	2,640 lb.	2,640 lb.
	Opt.	Limited slip	Limited slip
Transfer case	Std.	—	2-speed manual
	Opt.	—	Touch-Drive electric
Shock absorbers	Std.	Gas-pressurized	Gas-pressurized
Stabilizer bars	Std.	Front and rear	Front and rear
Springs:			
front	Std.	1,750 lb. (coil)	1,970 lb. (coil)
	Opt.	Computer-selected	Computer-selected
rear	Std.	2,168 lb. (leaf)	2,172 lb. (leaf)
	Opt.	Computer-selected	Computer-selected
Curb-to-curb turning diameter	Std.	32.4 ft.	32.4 ft.
Tires	Std.	4 P195/75R15SL all-season steel-belted (limited service spare)	4 P195/75R15SL all-season steel-belted (limited service spare)
	Opt.	Optional size and tread design steel-belted radials are available. Use adequate tires for type of service. Consult your Ford Dealer. Full-size conventional spare tire is available with optional swingaway spare tire carrier.	

OD = Overdrive

## DIMENSIONS

	2WD	4WD
<b>EXTERIOR</b>		
Wheelbase	94.0"	94.0"
Overall length	158.2"	158.2"
Overhang (front/rear)	28.2"/36.0"	28.2"/36.0"
Tread (front/rear)	56.9"/56.9"	56.9"/56.9"
Overall width	68.0"	68.0"
Overall height	68.2"	68.2"
Load floor liftover height	28.4"	28.4"
Liftgate opening height	34.3"	34.3"
Axle clearance (front/rear)	—/6.5"	6.3"/6.5"
Ground clearance at transfer case (unloaded)	—	9.3"
Angle of approach	—	29.3°
Angle of departure (loaded)	—	24.7°
Ramp breakover angle (loaded)	—	24.1°
<b>INTERIOR</b>		
Head room (front/rear)	39.5"/38.3"	39.5"/38.3"
Leg room (front/rear)	42.2"/35.2"	42.2"/35.2"
Hip room (front/rear)	54.8"/44.1"	54.8"/44.1"
Shoulder room (front/rear)	55.5"/56.7"	55.5"/56.7"
Width between wheelhouses	41.9"	41.9"
Cargo length — rear seat up	21.2"	21.2"
— rear seat down	52.5"	52.5"
Cargo volume — rear seat up	25.6	25.6
(cu. ft.) — rear seat down	64.9	64.9

## FEATURES AND OPTIONS

	XL	XL Sport	XLT	Eddie Bauer
● = Standard ■ = Optional				
<b>EXTERIOR</b>				
Dual rectangular halogen headlights	●	●	●	●
Black foldaway mirrors	●	●	●	●
Bright low-mount swingaway western mirrors	■	■	■	●
Bright front bumper and bright rear trailer-tow bumper, front and rear rub strips	●	●	●	●
Black front bumper and rear tubular bumper	●	●	●	●
Black windshield and quarter window moldings	●	●	●	●
One-piece, top-hinged liftgate	●	●	●	●
Outside swingaway spare tire carrier/cargo cover	■	■	■	●
Tinted windshield and side door windows	●	●	●	●
Grey tinted liftgate and rear quarter windows	●	●	●	●
Privacy Glass™ in rear quarter windows	■	■	■	●
Flip-open rear window	■	■	■	■
Rear window wiper/washer/defroster	■	■	■	■
Luggage rack	■	■	■	■
Tilt-up/open-air roof	■	■	■	■
Black grille with bright surround	●	●	●	●
Black grille with black surround	●	●	●	●
Chrome grille	●	●	●	●
Accent tape stripe	●	●	●	●
Deluxe tape stripe	●	●	●	■
Sport tape stripe	■	■	■	●
Unique two-tone paint	●	●	●	●
Deluxe two-tone paint	■	■	■	●
Sport Appearance Package	●	●	●	■
Sport wheel covers	●	●	●	●
Deluxe wheel trim	■	■	■	●
15" cast aluminum wheels	■	■	■	●
Deep-dish cast aluminum wheels	■	■	■	■
<b>INTERIOR</b>				
Color-keyed reclining front bucket seats, rear split fold seats	●	●	●	●
Knitted vinyl trim	●	●	●	●
Cloth and vinyl trim	■	■	■	●
Dual cloth and vinyl Captain's Chairs with matching rear split/fold seats	●	●	●	■
60/40 split bench seats with cloth trim	■	■	■	●
Color-keyed safety belts with comfort regulators	●	●	●	●
Color-keyed soft vinyl A-frame steering wheel	●	●	●	●
Deluxe leather-wrapped steering wheel	●	●	●	●
Floor console	●	●	●	■
Touch-Drive electric shift (4x4)	■	■	■	■
Color-keyed vinyl door trim panels with fully padded armrests	●	●	●	●
Wrapover cloth door trim with carpeted lower portion and map pockets	●	●	●	●
Full-length color-keyed cloth headliner	●	●	●	●
Front dome light with courtesy switches for both doors	●	●	●	●
Brushed pewter-tone instrument panel cluster finish applique	●	●	●	●

	XL	XL Sport	XLT	Eddie Bauer
<b>INTERIOR (Cont'd.)</b>				
Woodtone instrument cluster applique	●	●	●	●
Locking glove box	●	●	●	●
Flocked glove box with courtesy light	●	●	●	●
Inside hood release	●	●	●	●
Dual note horn	●	●	●	●
Fuel, temperature and oil pressure gauges, cluster alert lights and trip odometer	●	●	●	●
Tachometer	■	●	●	●
Interval wipers	●	●	●	●
Full-length, color-keyed carpeting	●	●	●	●
Bright aluminum scuff plates	●	●	●	●
Day/night rearview mirror	●	●	●	●
Color-keyed, padded visors with clip band on driver's side	●	●	●	●
Right-hand visor mirror	●	●	●	●
Pivoting front vent windows	●	●	●	●
Color-keyed quarter trim panels with padded armrests and three flocked storage compartments	●	●	●	●
Color-keyed vinyl inside spare tire cover	●	●	●	●
Electronic AM radio (may be deleted for credit)	●	●	●	●
Electronic AM/FM stereo radio with digital clock	■	●	●	●
Electronic AM/FM stereo radio with digital clock and cassette player	■	■	■	●
Premium Sound System	■	■	■	■
Light Group (1)	●	●	●	●
Power windows and door locks	■	■	■	●
Air conditioning	■	■	■	●
Speed control/tilt steering wheel	■	■	■	●
<b>MISCELLANEOUS</b>				
Limited-slip rear axle	■	■	■	■
Super engine cooling	■	■	■	■
Engine block heater	■	■	■	■
California emissions system	■	■	■	■
High altitude emissions system	■	■	■	■
Snow Plow Preparation Package (4x4)	■	■	■	■

(1) Includes ashtray light, cargo area light, glove box light, headlamps-on alert chime and engine compartment light.

## COLORS & TRIMS

Interior Trim Colors			Exterior Colors
Regatta Blue	Scarlet Red	Chestnut	
	X	X	Raven Black
	X	X	Scarlet Red
	X	X	Cabernet Red
X	X	X	Light Chestnut
	X	X	Colonial White
		X	Alpine Green Clearcoat Metallic*
X	X		Silver Clearcoat Metallic
X	X	X	Shadow Grey Clearcoat Metallic
X			Bright Regatta Blue Clearcoat Metallic
X			Deep Shadow Blue Clearcoat Metallic
	X	X	Light Chestnut Clearcoat Metallic
		X	Dark Chestnut Clearcoat Metallic

\* Available with Eddie Bauer only.



Raven Black



Scarlet Red



Cabernet Red



Light Chestnut



Colonial White

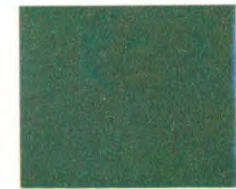

Alpine Green Clearcoat Metallic



Silver Clearcoat Metallic



Shadow Grey Clearcoat Metallic



Bright Regatta Blue Clearcoat Metallic



Deep Shadow Blue Clearcoat Metallic



Light Chestnut Clearcoat Metallic

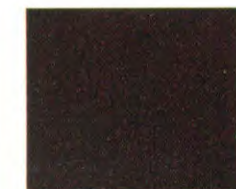

Dark Chestnut Clearcoat Metallic

# SAFETY AND OWNER BENEFITS

**F**ord Motor Company strongly encourages all passengers to use their safety belts.

In Ford Bronco II, front seat lap and shoulder belts have automatic retractors. And the rear seat positions also have lap belts with retractors.

Ford urges the use of child and infant restraints. Ford's easy-to-install Tot-Guard (for children 20 to 50 pounds) and Infant Carrier (for children up to 20 pounds) are available at all Ford Dealers. If a child restraint requires a top-tether, Bronco II provides special anchorages.



## Ford Lifeguard Design Safety Features

### Vehicle operation

- Split service hydraulic brake system with warning light
- Electronically controlled rear anti-lock brake system
- Corrosion-resistant brake lines
- Turn indicator with lane-changing signal feature
- Hazard warning flasher
- Backup lamps
- Parking lamps coupled with headlamps
- Side marker lamps
- Two-speed windshield wipers

- Windshield washers
- Dual outside rearview mirrors
- Glare-reduced instrument panel, windshield wiper arms and windshield pillars
- Uniform transmission shift quadrant with safety starting switch (on all vehicles equipped with automatic transmission)
- Continuously variable control illumination intensity (instrument cluster lighting)
- Safety hood latch system
- Function rated windshield defroster system
- Tamper-resistant (non-reversing) odometer
- Speedometer with high-lighted 55 mph

### Occupant protection

- Safety-designed front end structure
- Two-position safety door latches
- Integral lap and shoulder belts with automatic retractors for front outboard occupants
- Lap belt for center front passenger (with optional 60/40 split bench seat)
- Safety belt fastening reminder warning light and buzzer or chime for the driver's seat
- Lap belts with retractors for rear seating positions
- Energy-absorbing steering column and steering wheel
- Energy-absorbing armrests and safety-designed door handles
- Energy-absorbing instrument panel with padding for right front passenger (center front with optional 60/40 split bench seat)
- Energy-absorbing sun visors
- Energy-absorbing front seat back tops
- Self-locking seat back latches
- Head restraints for front outboard occupants
- Safety glove box latch
- Inside yield-away rearview mirror
- Impact-absorbing laminated safety glass windshield
- Flame-resistant interior materials

- Safety-designed coat hook
- Safety-designed radio control knobs and push buttons

### Anti-theft

- Locking steering column with key warning buzzer (with "Park" interlock or push button for key release)
- Visible vehicle identification number

### 6-year/60,000-mile powertrain warranty

Ford's powertrain warranty covers all 1988 cars and light trucks for 6 years or 60,000 miles, whichever comes first. This limited warranty covers major powertrain components. Certain restrictions and deductible apply. Ask your dealer for a copy.

### Scheduled maintenance

Here are some examples of scheduled maintenance intervals for the 1988 Bronco II. For complete recommendations, refer to the Bronco II Scheduled Maintenance Booklet.

Engine oil and filter change	each 7,500 miles or 6 months
Spark plug change	each 30,000 miles
Air filter replacement	each 30,000 miles
Engine coolant replacement	each 30,000 miles or 3 years

- 2-Sided galvanized metal
- 1-Sided galvanized metal
- Urethane anti-corrosion spray
- Plastic parts

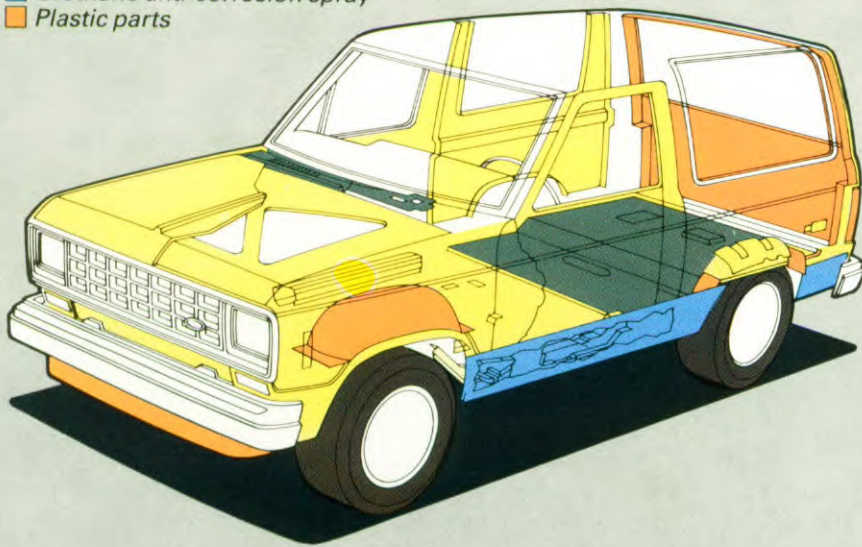

### Bronco II 6-year/100,000-mile corrosion protection

Bronco II's corrosion warranty coverage for body panel rust through is 6 years or 100,000 miles, whichever comes first. See your Ford Dealer for details and a copy of this limited warranty.



Participating Ford Dealers offer the Lifetime Service Guarantee, which guarantees their work on your Ford vehicle for as long as you own it. This means that the covered repair is paid for once — and never again. If it ever has to be fixed again, the repairing dealer will fix it free. Free parts. Free labor. Even if the car is kept a lifetime. It doesn't matter where it was purchased, or whether it's

new or used; the work is still covered by the repairing dealer. Ask to see this limited warranty when you visit your participating Ford Dealer.



**EXTENDED  
SERVICE  
PLAN**

Optional Ford Extended Service Plans cover major components on new Ford cars and light trucks for longer than the vehicle's basic warranty. The cost of this added protection is so moderate that it could pay for itself the first time you need it. Your Ford Dealer has full details.

**Motorcraft** 

**QUALITY REPLACEMENT PARTS  
FROM FORD**

Genuine Ford and Motorcraft original equipment replacement parts meet the same high standards as those installed in production.

**Ford  
Credit**

Ford Motor Credit Company is interested in helping to fill the transportation needs of every qualified buyer of a Ford product. A participating dealer can arrange financing terms or a Red Carpet Lease<sup>®</sup> tailored to your circumstances. Ford Credit has offices conveniently located throughout the United States.

**Ford-paid repair programs  
after the warranty period**

Sometimes Ford Motor Company offers adjustment programs to pay all or part of the cost of certain repairs. These programs are intended to assist owners and are in addition to the warranty or to required recalls.

**Technical service bulletins**

All vehicles need repairs during their lifetime. Sometimes Ford issues technical service bulletins (TSBs) and easy-to-read explanations describing unusual engine or transmission conditions which may lead to costly repairs, the recommended repairs, and new repair procedures. Often a repair now can prevent a more serious repair later.

**For more information...**

Ask Ford Motor Company or your Ford or Lincoln-Mercury dealer about Ford-paid repair programs and/or TSBs relating to your vehicle.

To get copies of materials for your vehicle or the vehicle of interest to you: Call Ford toll-free at 1-800-241-3673. Alaska/Hawaii call 1-800-241-3711 and in Georgia call 1-800-282-0959.

Or write Ford at:  
Ford Customer  
Information System  
Post Office Box 95427  
Atlanta, Georgia 30347

We'll need your name and address; year, make, model and vehicle identification number, as well as engine size.

**Options availability**

Options shown or described in this catalog are available at extra cost and may be offered only in combination with other options or subject to additional ordering requirements or limitations.

**Product changes**

Ford Division reserves the right to change product specifications at any time without incurring obligations.

**"Ask your Ford Dealer"**

Following publication of this catalog, certain changes in standard equipment, options, prices and the like, or product delays, may have occurred which would not be included in these pages.

Your Ford Dealer is your best source for up-to-date information.

**Buy or lease  
a new Bronco II**



*Your safety is a major concern at Ford. Do your part by always buckling up your safety belt.*



*The optional Tot-Guard is available at all Ford Dealerships.*

